



Butterfly Valve Installation Guide



Doc: BFLY-INFO/2

Jun 2008

General guide for installing butterfly valves

1) BEFORE STARTING TO INSTALL - YOU MUST HAVE THE CORRECT SIZE FLANGES FOR THE VALVE BEING INSTALLED

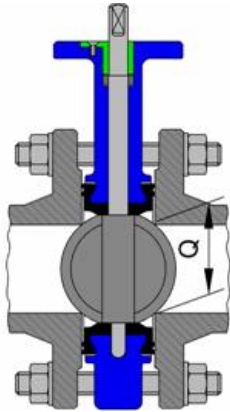

UNDERSIZE FLANGES

Undersize flanges will not clear the minimum disc clearance diameter 'Q', and will result in damage to the valve and flanges, and the valve will not function correctly.

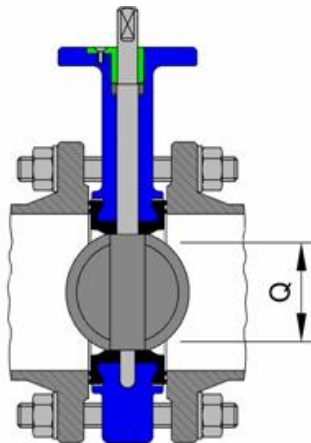

OVERSIZE FLANGES

Oversize flanges will prevent the correct compression of the valve's liner and are unlikely to seal on the flange faces. There is a strong risk of the liner collapsing as the valve operates.

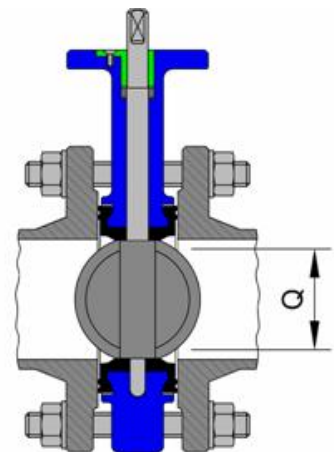

CORRECT FLANGES

Correctly sized flanges allow the valve to operate at its maximum design specifications as the liner seals correctly on the flanges, the disc is correctly contained within the liner, and the disc is free to rotate.



Butterfly Valve Installation Guide



Doc: BFLY-INFO/2

Jun 2008

General guide for installing butterfly valves

2) INSTALLING

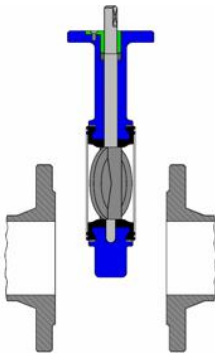

SPREAD THE FLANGES

This allows the valve to slide between the flanges.

Note that the disc is in the part open position but NOT protruding beyond the body

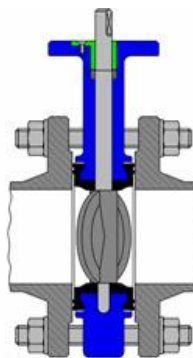

FIT THE BOLTS

Install the bolts but do not tighten yet. Ensure bolts pass through guide lugs on valves with lugs cast into the body, these are to assist in centralising the valve with the flanges. Valve still in the part open position.

DO NOT USE GASKETS

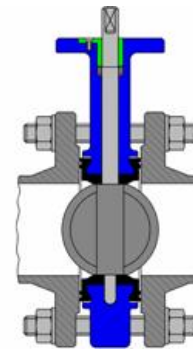

OPEN THE VALVE & TIGHTEN THE BOLTS

Open the valve to prevent the liner forming around the disc when the bolts are tightened, this reduces the initial operating torque. Tighten the bolts using the standard cross-wise method.

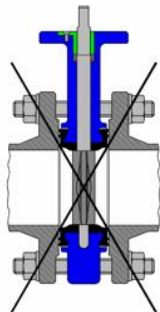

DO NOT TRY TO INSTALL THE VALVE WITH THE DISC IN THE CLOSED POSITION

Installing with the disc closed allows the liner to 'flow' around the disc creating a ridge either side of the disc when the bolts are tightened. This dramatically increases the initial torque required to move the disc over the ridge, and the extra torque required may exceed the maximum available torque from the actuator.

In our experience, in automatic butterfly valves, this is the biggest single cause of initial automatic malfunction

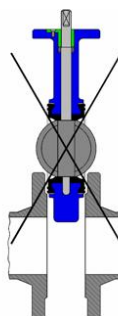

DO NOT TRY TO INSTALL THE VALVE WITH THE DISC OPEN BEYOND THE BODY

This will damage the disc which will in turn damage the liner when the valve is operated.



Butterfly Valve– stud lengths



Doc: BFLY-INFO/2

Jun 2008

BS 5155 Short pattern - *General dimensional information chart*

The information below should be used as a general guide for dimensions of studs to fix PN16 flanges to the different wafer pattern butterfly valve sizes, where the valve conforms to BS 5155 (Short Pattern)

Size	Face to Face BS5155	Thread Size	Slip on Flange Thickness	Stud Length	Quantity
50	43	M16	18	122	4
65	46	M16	18	125	4
80	46	M16	20	130	8
100	52	M16	20	135	8
125	56	M16	22	145	8
150	56	M20	22	150	8
200	60	M20	24	160	12
250	68	M24	26	180	12
300	78	M24	28	195	12
350	78	M24	30	200	16
400	102	M27	32	235	16
450	114	M27	34	250	20
500	127	M30	34	270	20
600	154	M33	36	305	20

Bolting Details

Bolt lengths are established from the following criteria:-

- Valve face to face - BS5155 (Short, Medium, Long Pattern)
- Flange Thickness - slip on flange (Code I11, I12 and I13) - BS4504 Section 3.1 (steel) PN 16 (to max. tolerance)
- Thread size - BS4504 Section 3.1 PN16
- Nut thickness - BS4882 Table 14
- Washer thickness - BS4320 standard Black Normal Series
- Stud lengths shown are minimum length